



# **TF-HDMI-3.3V 50 ohms Pull-up Terminator Quick Reference Guide**

**Revision A – September, 2008**

**Relating to the Following Release Versions:**

- **Software Version 5.6**

## LeCroy Corporation

700 Chestnut Ridge Road  
Chestnut Ridge, NY 10977-6499  
Tel: (845) 578 6020, Fax: (845) 578 5985

Internet: [www.lecroy.com](http://www.lecroy.com)

© 2008 by LeCroy Corporation. All rights reserved.

LeCroy, ActiveDSO, WaveLink, JitterTrack, WavePro, WaveMaster, WaveSurfer, WaveExpert, WaveRunner and WaveJet are registered trademarks of LeCroy Corporation. Other product or brand names are trademarks or requested trademarks of their respective holders. Information in this publication supersedes all earlier versions. Specifications subject to change without notice.

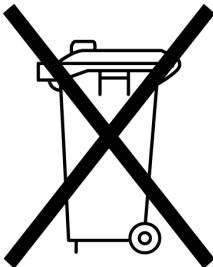
<p>Manufactured under an ISO 9000 Registered Quality Management System Visit <a href="http://www.lecroy.com">www.lecroy.com</a> to view the certificate.</p>		<p>This electronic product is subject to disposal and recycling regulations that vary by country and region. Many countries prohibit the disposal of waste electronic equipment in standard waste receptacles.</p> <p>For more information about proper disposal and recycling of your LeCroy product, please visit <a href="http://www.lecroy.com/recycle">www.lecroy.com/recycle</a>.</p>
--	--	---

916607-00 Rev A

## TF-HDMI-3.3V – 50 ohms Pull-up Terminator

### INTRODUCTION TO TF-HDMI-3.3V

HDMI Compliance test requires signals to be terminated with a 50 ohms pull-up to 3.3V when using direct cable measure.

The TF-HDMI-3.3V provides such a termination while transmitted the signal to the oscilloscope input. It is designed for full HDMI bandwidth so that the signal is integrally transmitted.

TF-HDMI-3.3V is compatible with all oscilloscopes with ProLink Input and software version 5.6.x.x or higher.

Specifications		
<b>Interface</b>	ProLink	
<b>Input Connector Type (SIG, TERM)</b>	SMA (f)	
<b>Output Connector Type</b>	BMA (m), ProLink	
<b>Input Coupling</b>	50 Ω - DC	
<b>Input Impedance</b>	50 Ω	
<b>Output Source Impedance</b>	50 Ω	
<b>Non-Destruct Input Range</b>	1.5 V min to 3.5 V max	
<b>DC Gain into 50 Ω</b>	0.20 +/- 1.5%	
<b>AC Gain</b>	-14 dB +/- 0.5 dB -14 dB +/- 1 dB	0 < frequency < 2 GHz 2 GHz < frequency < 10 GHz
<b>Input Return Loss</b>	> 20 dB > 15 dB > 10 dB	frequency <= 2 GHz 2 GHz < frequency <= 8 GHz 8 GHz < frequency <= 10 GHz
<b>S22</b>	> 6 dB	
<b>Risetime (10-90%)</b>	< 35 ps	
<b>Overshoot</b>	< 5%	20 ps risetime input

BLANK PAGE